

See discussions, stats, and author profiles for this publication at: <https://www.researchgate.net/publication/313952194>

# On the use of an Arduino-based controller to control the charging process of a wind turbine

Conference Paper in AIP Conference Proceedings · February 2017

DOI: 10.1063/1.4976284

---

CITATIONS

4

---

READS

4,581

3 authors, including:



Faisal Mahmuddin

Universitas Hasanuddin

22 PUBLICATIONS 66 CITATIONS

SEE PROFILE

Some of the authors of this publication are also working on these related projects:



Floating Breakwater Shape Optimization [View project](#)



Ship Motion Energy Conversion [View project](#)

# On the use of an Arduino-based controller to control the charging process of a wind turbine

Faisal Mahmuddin, Ahmad Muhtam Yusran, and Syerly Klara

Citation: [AIP Conference Proceedings](#) **1814**, 020065 (2017); doi: 10.1063/1.4976284

View online: <http://dx.doi.org/10.1063/1.4976284>

View Table of Contents: <http://aip.scitation.org/toc/apc/1814/1>

Published by the [American Institute of Physics](#)

---

---

# On the Use of an Arduino-based Controller to Control the Charging Process of a Wind Turbine

Faisal Mahmuddin<sup>1, a)</sup>, Ahmad Muhtam Yusran<sup>1, b)</sup>, Syerly Klara<sup>1, c)</sup>

<sup>1</sup>*Marine Engineering, Engineering Faculty, Hasanuddin University  
Jalan Perintis Kemerdekaan km. 10, Tamalanrea, Makassar, Indonesia*

<sup>a)</sup>Corresponding author: f.mahmuddin@gmail.com

<sup>b)</sup>ahmadmuhtam@gmail.com

<sup>c)</sup>elikapal@yahoo.com

**Abstract.** In order to avoid an excessive charging voltage which can damage power storage when converting wind energy using a turbine, it is necessary to control the charging voltage of the turbine generator. In the present study, a charging controller which uses an Arduino microcontroller, is designed. 3 (three) indicator lights are installed to indicate the battery charging process, power diversion to dummy load and battery power level. The performance of the designed controller is evaluated by simulating 3 cases. In this simulation, a battery with maximum voltage of 12.4 V is used. Case 1 is performed with input voltage equals the one set in Arduino which is 10 V. In this case, the battery is charged up to 10.8 V. In case 2, the input voltage is 13 V while the maximum voltage set in Arduino is also 13 V. In this case, the battery is charged up to maximum voltage of the battery. Moreover, the dummy load indicator is ON and charging indicator is OFF after the maximum charging voltage is reached because the electricity is flowed to the dummy load. In the final case, the input voltage is set to be 16 V while the maximum voltage set in Arduino is 13 V. In this case, the charging indicator is OFF and dummy load indicator is ON which means that the Arduino has successfully switched the power to be flowed to dummy load. From the 3 (three) cases, it can be concluded that the designed controller works perfectly to control the charging process of the wind turbine. Moreover, the charging time needed in each case can also be determined.

## INTRODUCTION

Nowadays, it is well known the usage of conventional fossil energy has been destructive to the earth's environment. Moreover, continuous use of this kind of energy has made its reserve is reducing. In addition, considering economic factors when using fossil energy has also become another disadvantage of using thing kind of energy. According to these reasons, it is essential to explore and utilize natural and renewable energy sources available on earth. One of the potential renewable energies with a high prospect is wind energy. The prospects is due to its clean and sustainability characteristics in producing electric power as well as not damaging the environment. Moreover, harvesting the wind energy can be considered to be relatively easier as compared to other kinds of renewable energies [1]. The energy is not only abundantly available in land but also in ocean [2].

However, several problems are also faced when harvesting the wind energy. One of the main problems that often occurs is the erratic voltage changes caused by uncertain wind speed. The uncertain charging voltage can damage the power storage. Therefore, it is necessary to control the charging voltage of the turbine generator in order to protect the power storage due to its excessive charging voltage.

For the purpose of preventing damage of the power storage due to an excessive charging voltage of generator, a device is needed to control the charging voltage when charging the power storage. This voltage controller will protect the power storage by detecting the generator voltage and control the flow of the electricity according to the voltage level of the charging [3, 4].

The controller that will be used in the present study is based on an Arduino microcontroller which will make it easy to use and adjust according to the needs. In this controller, several indicator lights are also installed to indicate several important parameters in charging process which are battery charging process, power diversion to dummy load and battery power level. In order to evaluate the performance of the system, 3 (three) cases are simulated in the present study. From the simulation, it can be shown that the proposed controller design could effectively control the voltage and protect the excessive voltage charging from generator to power storage.

## WIND TURBINE SYSTEM

Wind turbines is a tool to convert wind energy (kinetic energy) to electrical energy. The popularity of wind turbine has been increased in recent decades. Based on data from the WWEA (World Wind Energy Association) [5], until the year 2007, the electricity generated by wind turbines has reached 93.85 GW which means it produces more than 1% of the total global electricity. The United States, Spain and China are the leading countries in the exploration and utilization of wind energy. It is well known that profitable turbines are the ones with large scale. However, small scale wind turbines also have an important role, especially for areas that have not been reached by the standard electricity network (grid).

### Wind Energy Conversion

Wind energy conversion is the utilization of a source of energy by using wind turbines. Mechanical energy converted by the wind turbines can be used directly or saved in a power storage. The utilization of mechanical energy directly occurs because of the wind which moves leaves the turbine causing the turbine to spin. The rotation of the turbine causes the formation of a mechanical energy. The conversion of wind energy into electrical energy occurs through the spinning turbine vanes. From the turbine rotation causes the generator to experience a turnaround. Inside the generator, the motion energy of the wind is converted into electrical energy. However, not all power of the wind can be converted into electrical energy due to several losses [6].

Wind energy is a natural resource that can be obtained for free and abundantly available continuously throughout the year including in Indonesia. Because Indonesia is an archipelago country which has about 17.500 islands with long coastline of over 81.290 km, Indonesia has a very large wind energy potential. It estimated that Indonesia has about 9.3 GW of new capacity. However, of the capacity, only currently total installed is about 0.5 MW [7]. Therefore, the research about wind energy utilization in Indonesia is important to be conducted.

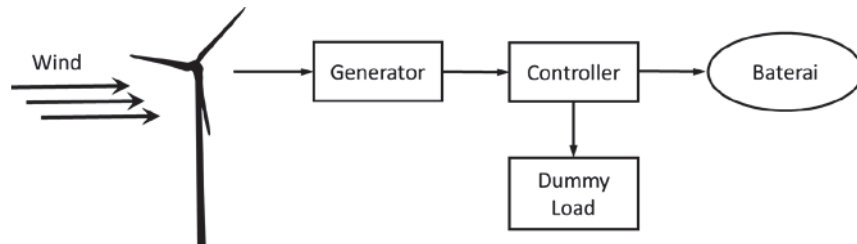

**Figure 1.** Wind turbine research focuses

In conducting research about wind turbine, several components have to be taken care such as the turbine, generator, power storage, etc as shown in the Fig. 1. Therefore, the present study will focus on developing controller system which will connect generator and power storage.

### Battery Charger

Battery charger is a device that is used to fill the battery with constant current or constant power until the battery reaches its maximum voltage. When the maximum voltage level is reached, the charging current will drop automatically to a secured level and it will hold the charging current to be slower so that the power indicator will be ON to indicate that the battery is fully charged. Each battery has its own tolerant voltage to accept different currents so that it could not be charged with any current. If it is charged above maximum level for long time, the battery could be damaged. Therefore, it is important to charge the battery with the allowed specified voltage.

## Accumulator

Accumulator or commonly known as battery is one of the main components in motor vehicles, both cars and motorcycles. The battery is required to turn on the vehicle's engine (distributing current dynamo starter of vehicles). Accumulator produces energy by converting chemical energy to electrical energy. There are 2 (two) main elements in accumulator, namely primary and secondary element. The primary element is composed of elements and wet. The primary element in a chemical reaction causes the electrons flow from the negative electrode (cathode) to the positive electrode (anode) which cannot be reversed in direction. When the electric runs out, then the primary element cannot load back and it requires replacement of the reactant materials (elements). The most common used accumulator which uses dry cell as primary elements is a batteries.

### Charge and Discharge Processes

Battery (accumulator) is one of the energy storage medium that is commonly used on motor vehicles. It is used to power the vehicles lamps, starting ignition, etc. In the present study, the battery will be used to store the electrical energy harvested by wind turbine. The charging and discharging of a battery can be performed with constant current or constant voltage. In order to know the time in the process of charging of the battery, the following equation can be used

$$T_d = \frac{A_h}{A} \quad (1)$$

where

$T_a$  = current charging duration (hours)

$A_h$  = accumulator capacity (ampere hours)

$A$  = current charging into the accumulator (ampere)

In terms of power, it can be determined by the following formula

$$T_d = \frac{\text{Power } A_h}{\text{Power } A} \quad (2)$$

where

Power  $A_h$  = multiplication of accumulator voltage with  $A_h$  (watts hours)

Power  $A$  = power of multiplication accumulator voltage (watts)

## ARDUINO MICROCONTROLLER

Arduino UNO is a single-board microcontroller and a software suite for programming it. This Board has 14 digital input/output pins (6 pins can be used as PWM outputs), 6 analog inputs, a 16 MHz crystal oscillator, a USB connection, jack power reset button. These pins contain everything needed to support the microcontroller. It would just need to connect the arduino to the computer with the USB cable or the voltage source can be obtained from DC-AC adapter or battery to use it.

Language programs used in Arduino is C language. The language is one of the most commonly used programming languages especially for basic programming on a controller. Another advantage of using arduino is the availability of the tutorial which is very easy to find. There are many type of Arduino but the latest and the most popular one is arduino Uno. An example of Arduino Uno is shown in the following figure

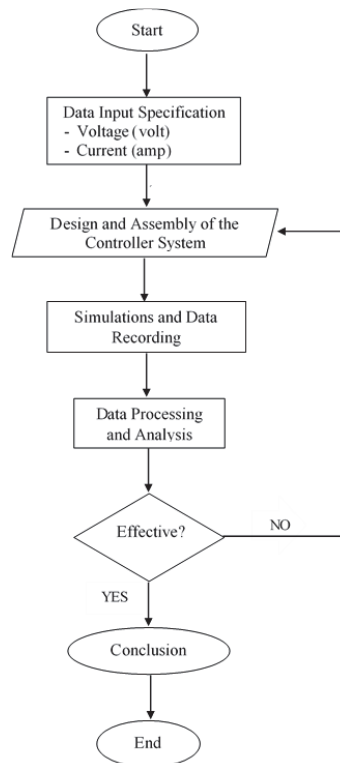

**Figure 2.** Arduino Uno example [8]

The main difference of the Arduino Uno with the previous versions is that it does not use the FTDI USB-to-serial driver chip. Instead, it uses an Atmega8U2 programmed as a USB-to serial converter. This gives the board several advantages over its predecessor known as Duemilanove. These advantages are the board is a lot cheaper than the FTDI chip and it enables the USB chip to have its firmware reflashed to make the Arduino connected and show up on computer as a different device, such as a mouse or game controller. In order to program the Arduino, C language codes are written in the Arduino IDE (Integrated Development Environment). The computer program that is written in the IDE is a set of step-by-step instructions known as sketches that will be uploaded to the Arduino. The Arduino will carry out these instructions and interact with whatever devices which have been connected to the board. The Arduino hardware and software are both open source, which means that the code, schematics, design, etc. can be downloaded and modified freely by anyone [8].

## CONTROLLER DESIGN AND ASSEMBLY

In order to achieve the objectives of the study, several steps of study are conducted. They are shown in the the following flowchart



**Figure 3.** Workflow of working procedure

As shown in the figure above, data input which are voltage and current will be specified. These information will be necessary in determining the charger controller system components. After the system is designed and assembled, simulation and data recording steps are performed. The obtained data are then processed and analyzed. If the designed system is optimal, then conclusion will be drawn. Otherwise, the system will be redesigned.

In designing the system, several main components are assembled into one unit. The components and the way they are connected are shown in the following figure

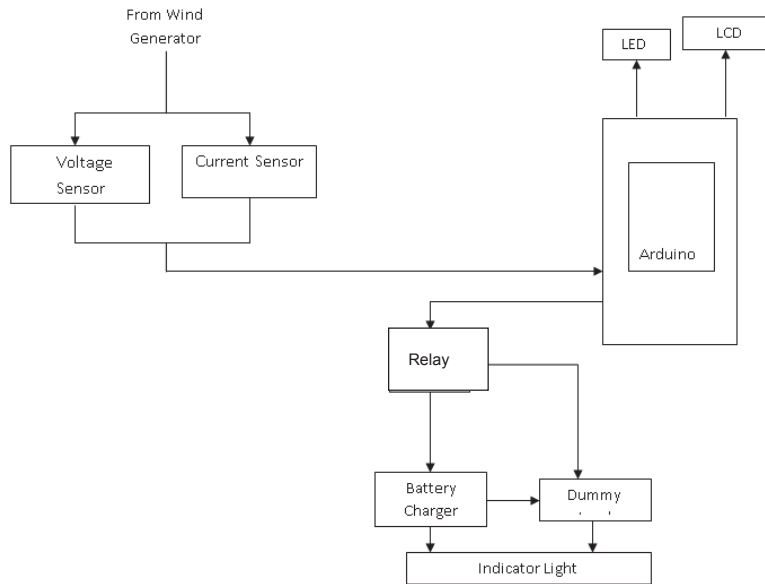
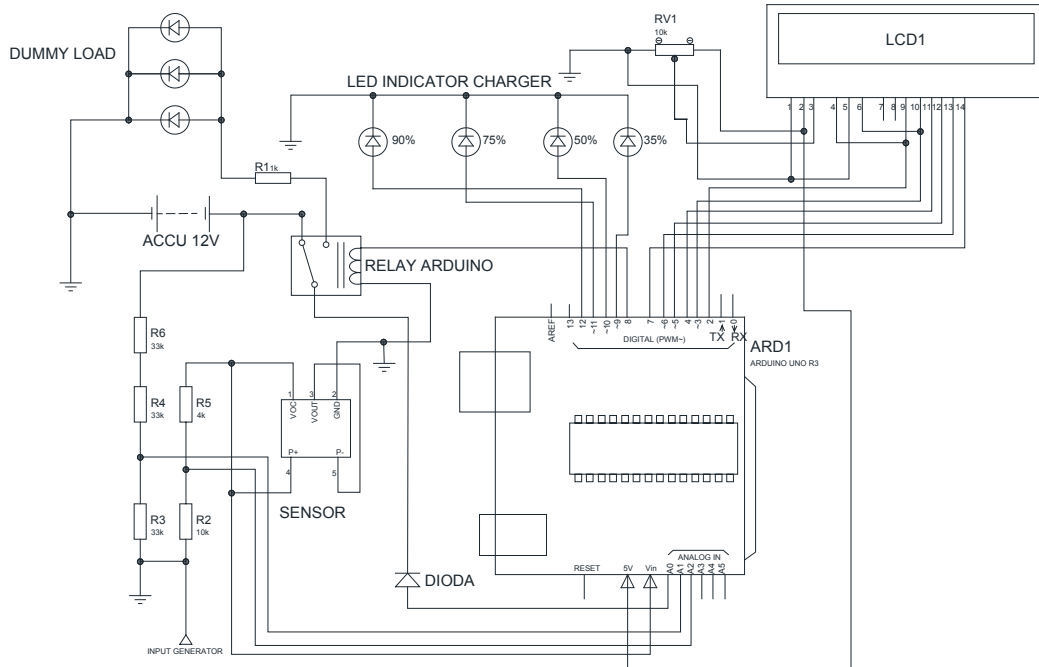

**Figure 4.** Charger components connection and workflow

From the flowchart above we can see that electricity (voltage and current) from wind turbine generators will be flowed to the Arduino. Arduino will then detect the amount of voltage and current voltage and current sensors. The amount of voltage and current will be display in an LCD screen. From Arduino, the electricity is flowed to the relay as a switch. Depending on the amount of the voltage, the electricity will be flowed to power storage when the voltage is smaller than the maximum allowable voltage set in Arduino or it will be flowed to dummy load when it is larger than the limit specified by the Arduino. The electricity will be flowed to dummy load not only because of excessive voltage, but also when the battery is full. In order to indicate the processes, 3 kinds of indicator lights are installed which are:

- Battery power level indicator. The indicator is installed to know the batteray power level. It consists of 4 LED lights where each light represents 25% of battery power.
- Charging indicator light. The indicator is used to know the charging process. The indicator will be ON when the charging is in the process and OFF when not charging
- Dummy load indicator Lights. The indicator will show whether the electricity is flowed to batteray or switched to dummy load. The indicator will OFF when the electricity is flowed to batteray and ON when the electricity is switched to dummy load.

The system connection in more details are shown in the following wiring diagram.



**Figure 5.** Controller system wiring diagram

As shown in the above diagram, the controller system consists of several main components such as controller relay, current sensor, LCD, potentiometers, resistors, LEDs, and the Arduino microcontroller as the central control of all components. Using the wiring diagram shown in Fig. 5, the hardware are assembled into one unit. The assembled model is shown in the following figure

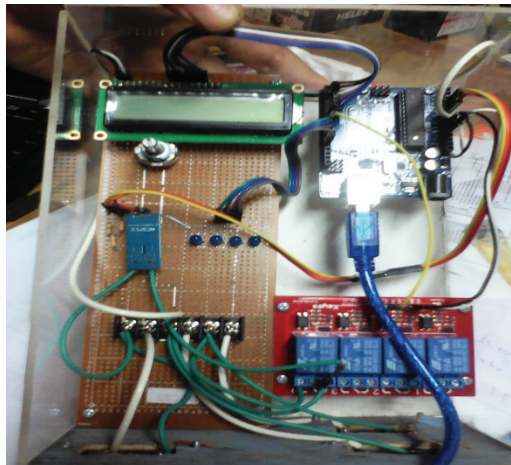

**Figure 6.** Assembled charging controller system

## SIMULATION AND ANALYSIS

In order to evaluate the performance of the system, 3 cases of simulation will be performed. The first case is when the input voltage is set below the maximum battery voltage, the second case is when the input voltage is above the maximum battery life, and the last case is when the input voltage is above the maximum battery voltage. In this simulation, the electricity produced by generator is replaced by a power supply as the input supply. The power supply is used to fill the battery has voltage range of 8-16 V.

### Case 1 (input voltage less than maximum battery voltage)

The main purpose of this case is to know the process of charging the battery when the input voltage is less than maximum battery voltage. In this case, the batteries have initial voltage of 8 V. The power supply is set to charge battery with 10 V voltage. In addition, the allowable maximum voltage set in controller is 10 V.

The charging time and process are shown in the following figure

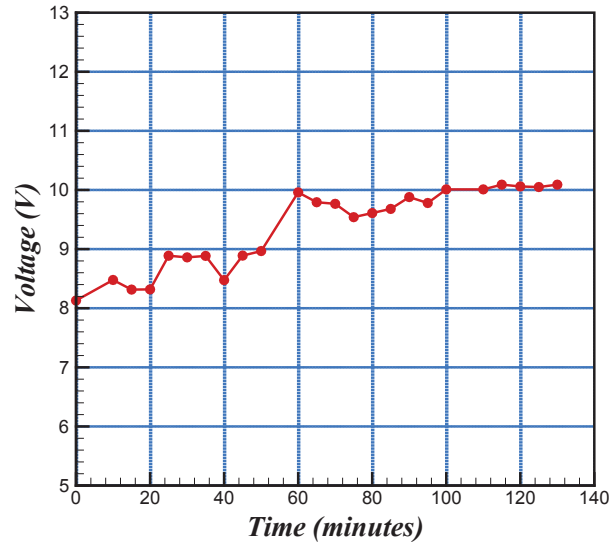

Figure 7. Charging time and voltage of 1<sup>st</sup> case

The graph above shows that the input voltage with charging time below the maximum voltage, power supply was only able to charge the battery up to 10.8 V and charging reached 75% of the voltage characteristics of the battery of 12 V. When the battery has reached a voltage of 10 V, Arduino controller switches the electrical current and voltage to dummy load. The switching will cause the dummy load indicator to be ON as shown in the following figure

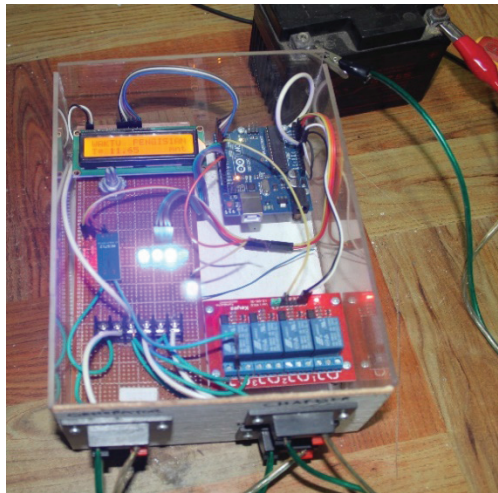

Figure 8. The dummy load is ON when the input voltage is switched to dummy load

When charging with the input voltage is below the maximum voltage, power supply was only able to charge the battery up 10.8 V and charging reached 75% of the characteristics of the battery of 12 V. This means 3 battery power indicator will be ON. When the battery has reached a voltage of 10 V, Arduino controller will divert electrical current and voltage to the dummy load.

## Case 2 (Input Voltage equal to Maximum Battery Voltage)

The main objective of the second case is to know the time and process of charging when the input voltage is equal to maximum battery voltage. Therefore, the testing is performed by setting the power supply input voltage to be 13 V. In addition, the maximum allowable voltage set in arduino is set to be also 13 V which is larger than the battery voltage capacity (12.4 V).

The time and process of charging in the second case is shown in the following figure

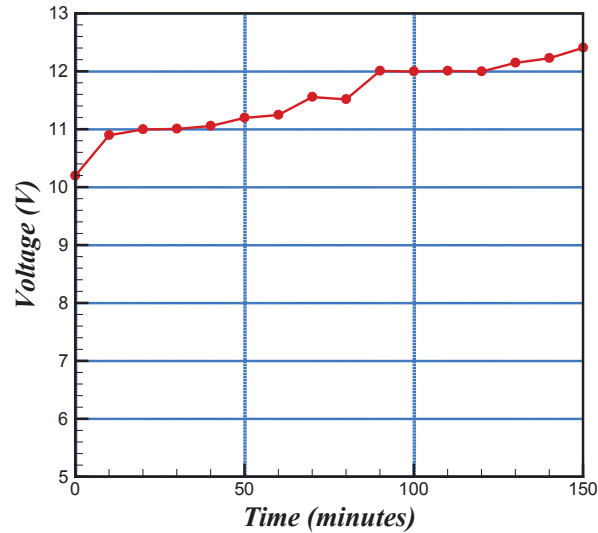

Figure 9. Charging time and process of 2<sup>nd</sup> case

The graph above shows that when charging with an input voltage of 13 V, the charger can charge the battery up to 100% of the battery voltage characteristics of 12.4 V. At this time, 4 pieces of LED indicators as well as the dummy load indicator are ON. This is because the electricity is switched to the dummy load when the battery is already full.

The view of the controller when the battery voltage has reached its maximum voltage is shown in the following figure

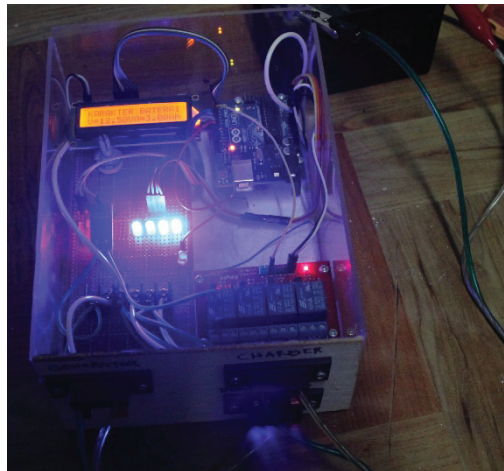

Figure 10. LED indicators (red light) is ON when not charging

The switching to dummy load is performed to protect the battery from continuous deep charging.

### Case 3 (Input Voltage larger than Maximum Battery Voltage)

The main objective of the final case is to confirm whether the control system is able to switch the electricity to dummy load when the input voltage is larger than the maximum battery voltage. Therefore, the test is performed with input voltage of 16 V while the maximum allowable voltage input is set to be 13 V. From this case, it is found that the electricity is transferred to dummy load due to voltage 16 V exceeds the range of charging maximum of 13 V. Moreover, the indicator light turns on and the dummy load charging indicator is turned off.

The view of the controller system in this case is shown in the following figure

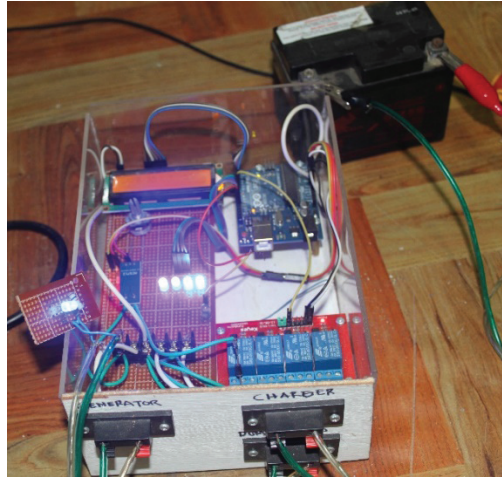

Figure 11. LED indicators dummy load when it is ON.

From the results of the test cases above, it can be concluded that the charger controller works as desired to limit the input voltage and the voltage maximum battery. Moreover, it can also be shown that the indicator lights also are useful to indicate the processes.

### SUMMARY

In the present study, 3 (three) cases are performed to evaluate the performance of the designed system. It found from the simulation that when the charging voltage exceeds the setting voltage, the electric produced by a power supply is switched to dummy load as well as when the battery is full. Moreover, it is found that amongst different voltage of 10 V, 13 V, and 16 V, only the case with input voltage of 13 V that can fill up the battery up to its maximum level. Based on data analysis performed in this study, it could be concluded that the charging system control designed in the present study could work according to the expected results.

### ACKNOWLEDGMENTS

This work was supported by Unggulan Perguruan Tinggi (UPT) research grant from Indonesian Directorate General of Higher Education and Hasanuddin University, Makassar for fiscal year 2014-2016.

### REFERENCES

1. M. Nakajima, S. Lio, and T. Ikeda, "Performance of Savonius Rotor for Environmentally Friendly Hydraulic Turbine", *Journal of Fluid Science and Technology*, Vol. 3, No. 3, 2008, pp. 420-429.
2. F. Mahmuddin, "Analysis of Wind Energy Potential with a Mobile Floating Structure around Sulawesi and Maluku Islands of Indonesia", *Proceeding of the 34<sup>th</sup> International Conference on Ocean, Offshore, and Arctic Engineering (OMAE)*, St. John's, Canada, Vol. 9, May 2015.
3. A. Ndiaye, C.M. F. Kébé, V. Sambou, and P.A. Ndiaye, "Development of a Charge Controller Dedicated to the Small Wind Turbine System", *Energy and Environment Research*, Vol. 4, No.3, 2014, pp. 68-77.

4. A. S. Myint, H.M. Tun, and Z.M. Naing, "Implementation of Wind Turbine Controller Design for Smart Campus", International Journal of Scientific and Research Publications, Vol. 4, No. 5, 2014, pp. 1-10
5. World Wind Energy Association, Half Year Report, WWEA, Bonn, 2014.
6. K.R. Ajao, and J.S.O. Adeniyi, "Comparison of Theoretical and Experimental Power output of Small 3-bladed Horizontal-axis Wind Turbine", Journal of American Science, Vol. 5, No. 4, 2009, pp. 79-90.
7. Y. Daryanto, "Study of Wind Energy Potential for Wind Energy Power Plant", Balai PPTAGG - UPT-LAGG, 2007. [in Bahasa]
8. M. McRoberts, "Beginning Arduino", Springer, New York, 2010.